

PRODUCT SPECIFICATIONS

# SS38DV Direct Vent Gas Stove

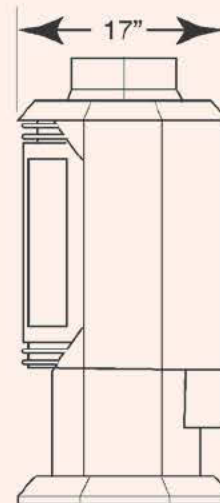
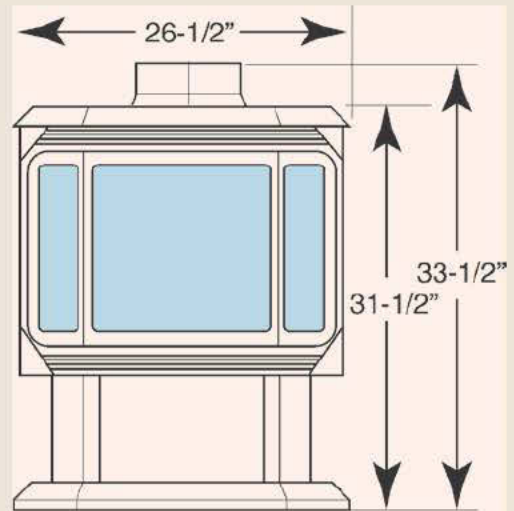

### INTERIOR DIMENSIONS

Width: 26-1/2"

Height: 31-1/2"

Depth : 17"

### TECHNICAL INFORMATION

Shipping Weight (Lbs): 170

Heating Capacity (Sq. Ft.): 1,800

Fire Viewing Area (Sq. inch): 316

Flue Size: 4" x 6-5/8"

Fan: 160 cfm

BTU/hr Input Rate (NG): 27,000 - 38,000

BTU/hr Input Rate (LP): 25,000 - 35,000

Thermal Efficiency (%): Up to 80

P4 EnerGuide Rating: NG: 80.1% LP: 81.8%

Clearances: Back: 6" Side: 9" Corner: 6"

CSA Design Certified

### FIELD INSTALLED ACCESSORIES

High Altitude Kit (NG): (SS38HAKN)

High Altitude Kit (LP): (SS38HAKP)

Conversion Kits Available



A Brand of Monessen Hearth Systems Co.  
149 Cleveland Drive, Paris, Kentucky 40361

[www.monessenhearth.com](http://www.monessenhearth.com)

